

MANTRA NT Advanced Process Control System

an advanced system for serious process control engineers



Open platform

For unit process applications designed for better quality, higher productivity, and reduced tolerance for errors, you need a small yet advanced control system--a system powerful enough to easily meet your application processing needs well into the next millennium. Introducing the new and powerful MANTRA Advanced Process Control System, ControlSoft brings to the process market a unique product which fits a broad range of continuous and batch control requirements.

MANTRA is extremely sophisticated for its size. Complete with a state-of-the-art object-based function block programming style and ActiveX-compliant display objects for performing HMI functions, MANTRA offers more than 80 function block programs that allow you to build complex control strategies.

From single PID to multistage cascade, multi-parameter PID, and even self-tuning blocks, MANTRA offers a superset of programming blocks found on most programmable logic and distributed control systems. The hardware platform is open and configured per each user's system requirements.

The open control system philosophy of MANTRA permits running on either an NT operating system on a PC-PLC architecture or a rack-based configuration complete with local and remote I/O and Ethernet support. The system is modular in architecture with integrated HMI and loop management software, but may also be configured to integrate with popular supervisory HMI systems.



Intuitive programming

Powerful process control functions stand out at the core of the MANTRA control system. These functions are the result of years of design experience and development by internationally known experts in control.

In addition to following the function block programming style laid out in IEC 1131-3, the development environment adds extensions and enhancements (made possible by its object-oriented design) to make life a little simpler for developers of control strategies.

You can select, link, and configure control blocks by dragging and dropping from a library of over 80 powerful algorithms. MANTRA process control software comes with unique new features such as:

- control variable watch lists
- an HMI software module where display screens can be built by picking and configuring from an extended library of objects and control block faceplate objects.



Advanced control

MANTRA extends the power of basic regulatory control functions by adding a powerful suite of model-predictive control algorithms.

Three advanced process control blocks are available:

- Internal Model Control (IMC),
- Coordinated Control (CC 1x3), where multiple control efforts control a single measured variable, and
- Modular Multivariable Control (MMC 2x3), which is a complete multi-input multi-output control block.

This control block suite is field-proven, and has been running successfully on a variety of DCS systems over the past five years in petrochemical, refinery, food processing, pulp and paper, and other applications. The CC and MMC control algorithms are patented by ControlSoft, and are widely known for their ease of use and similarity to traditional PID controllers in their setup and use.

The PID-based control strategies are available with proven self-tuning routines and Active-X faceplates with on-screen tuning functions.

An easy-to-use, intuitive system which can be programmed and configured with a minimum of formal training

MANTRA, a modular distributed process controller

The MANTRA system is based on the concepts of PC-based open control while preserving the superiority of a rack-based control system hardware that meets industrial installation and maintenance requirements.

Migrating from the traditional PLC and multi-loop controller architecture

MANTRA offers the benefits of an extremely powerful process controller on a small systems architecture.

Traditionally, the needs of a complicated process control application would be met by a PLC system, in spite of the lack of process control tools. Process integrators who are well versed in Ladder Logic spend enormous amounts of engineering time building process control schemes which naturally belong to the world of the DCS.

MANTRA meets the needs of small process control applications (those where the size of the application does not warrant the investment in a full DCS) by offering extremely powerful process control algorithms, state-of-the-art programming tools, integrated graphic displays, and DDE connections to third-party applications software.

Now there is no need to invest in a full DCS or compromise on a PLC-based architecture when choosing the right control system for your process control applications.

PROGRAMMING/RUNTIME/
SCADA TERMINAL



MANTRA NT SYSTEM ARCHITECTURE

Open OPC Client/Server System

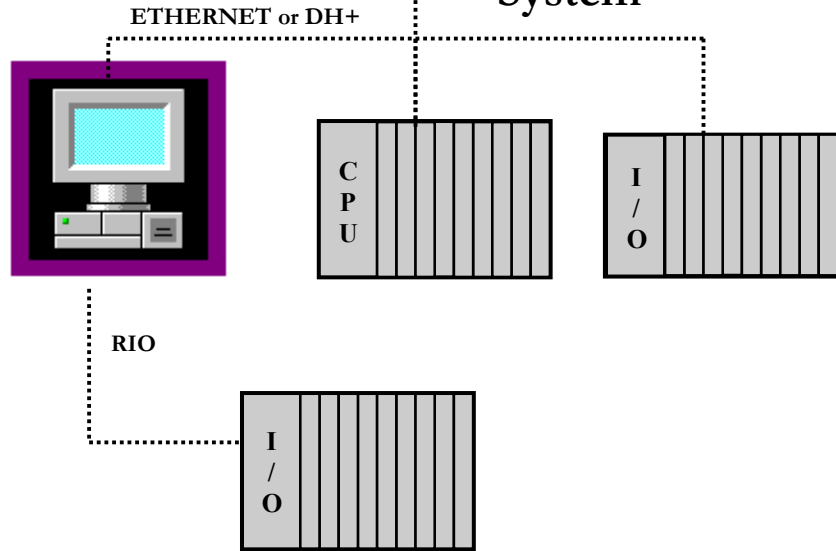

System configuration

MANTRA provides graphical system configuration tools to configure the hardware racks, I/O modules, network connections, and everything else needed to glue the system together.

The system configurator allows the user to easily choose any combination of I/O modules and configure them based on application requirements. It also provides system diagnostics.

The MANTRA system configurator resides on the NT station, which is a node on the Ethernet or DH+ network.

MANTRA system components

The MANTRA system is comprised of the following:

- (A) MANTRA NT controller
- (B) System I/O Local & Expansion racks
- (C) MANTRA NT configuration software
- (D) MANTRA NT Faceplates software
- (E) MANTRA NT Advanced Control license (optional)
- (F) MANTRA DDE/OPC software

Function block configurator

Process control engineers have pushed the envelope of advancements in control system design by demanding tools that permit intuitive building of basic and advanced control schemes.

MANTRA helps achieve that objective, by providing state-of-the-art programming tools which use object-oriented design technology. Every control block is an object which can be dragged and dropped on the worksheet and connected by a click of a mouse to build a viable control strategy.

Several new design features incorporated in the MANTRA configurator help reduce your control programming time by over 50%. Since each block is treated as a configurable object, it can be manipulated graphically, for example, to add inputs, to change tunable parameters to signal wires, or to encapsulate several blocks within one.

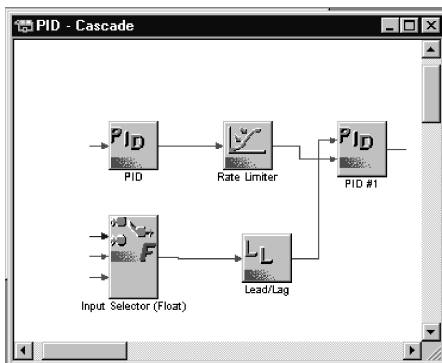

For debugging and operation, the software provides configurable watch lists which let the user take a peek at any variable running in the kernel. The software also allows configuration of ActiveX-based run-time faceplates which can further be easily integrated with ActiveX-compliant HMI supervisory workstations.

Parameter Name	Current Value	Parameter Type
PID.PV	0	Input
PID.SP	0	Tunable
PID.CO	0	Status/Output
PID.P	1	Tunable
PID.I	0	Tunable
PID.D	0	Tunable
PID.Auto-Manual	Manual	Tunable

Sequence function chart

Process control applications are mostly a mixture of batch and continuous regulatory control operations. While function block programming techniques make it intuitively easy to build PID and other continuous control schemes, the SFC programming tool within MANTRA helps build a batch program with equal ease and flexibility.

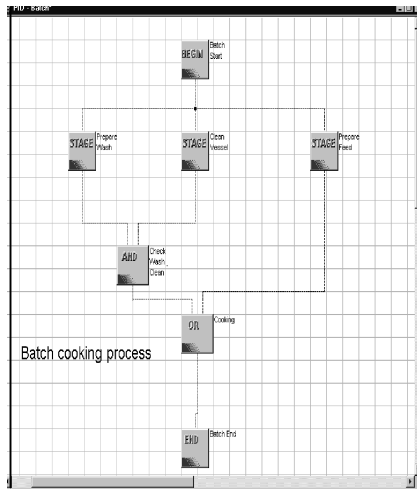

Creating complex process control schematics

MANTRA users are provided with an extensive library of process control functions (over 80) which allow for development of any continuous, batch, or discrete control scheme.

The function library includes configurable PID-based strategies, including advanced schemes such as feedforward with dynamic compensation, ratio and cascade control, adaptive gain PID, arithmetic, logical, and time-based functions.

Discrete operations like drum sequencing, FIFO/LIFO operations, latching, etc., are standard functions within the block library, which includes logical blocks, thus enabling programming of Boolean operations.

MANTRA supports a mixture of continuous and batch control schemes that enable users to configure multiple PID or model-based control schemes or easily add a supervisory batch strategy.

Faceplates

MANTRA provides a toolbox of ActiveX controls (graphical objects like slide bars, trend charts, switches, display meters, etc.) which the user can manipulate freely and can collect to build several pages of graphical displays.

Several graphical objects are also pre-configured as faceplate displays -- from the very simple PID block to cascade PID, IMC, and even multivariable control blocks like MMC and CC.

The availability of preconfigured displays translates to less time required for building detailed display screens for the control system. For example, a preconfigured PID faceplate may be dropped and connected to a block with a few keystrokes and, when on-line, would provide complete functional links such as auto-tuning, switching a loop from auto to manual, and changing tunable parameters.

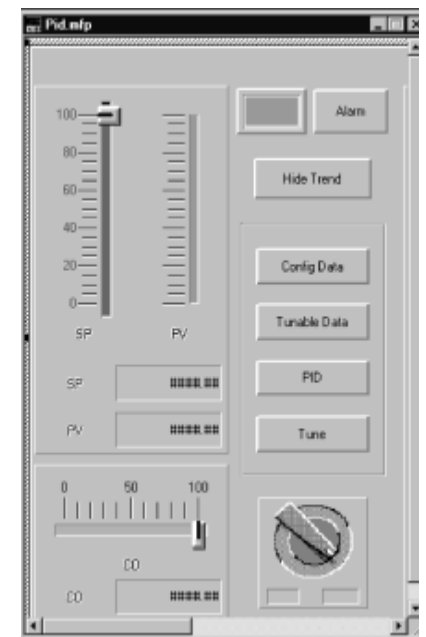

Advanced control applications using MANTRA

MANTRA is designed to solve advanced control applications on a wide variety of continuous and batch processes in the chemical, petrochemical, paper, plastic, food, pharmaceutical, and metal industries.



Some examples of control loops which require advanced functions beyond the classical PID are outlined below:

- pH and chlorination control in water treatment
- Billet temperature coordinated control
- Moisture control on a paper machine system
- Fermentation coordinated control
- Reactor control in resin manufacturing
- Furnace and forehearth control in the glass industry
- Moisture control in the food industry